



● Electrical characteristics(Ta=25°C)

Parameter	Symbol	Condition	Min.	Typ.	Max.	Unit
Supply Voltage	VDD	-	4.5	5.0	5.5	V
Input Voltage Level	VIH	Din High Level	0.7*VDD	-	-	V
	VIL	Din Low Level	-	-	0.3*VDD	V
Static current	IDD	VDD = 4.5V , Iout "OFF"	-	0.5	-	mA
R/G/B Constant Current	Iout	-	17	18	19	mA
Frequency of Clock signal	FCLK	-	-	0~5	15	MHz
Frequency of PWM	FPWM	-	-	20	-	KHz
The clock high level width	tCLKH	-	30	-	-	ns
The clock Low level width	tCLKL	-	30	-	-	ns
Data set up time	tSETUP	-	10	-	-	ns
Data hold time	tHOLD	-	5	-	-	ns

● Optical characteristics(Ta=25°C)

Parameter	Symbol	Condition	Min	Typ	Max.	Unit
Luminous Intensity	IV(R)	Iout=18mA	580	900	1305	mcd
	IV(G)	Iout=18mA	1070	1600	2400	mcd
	IV(B)	Iout=18mA	259	400	583	mcd
Dominant Wavelength	WLD(R)	Iout=18mA	620	625	630	nm
	WLD(G)	Iout=18mA	520	525	530	nm
	WLD(B)	Iout=18mA	460	465	470	nm
View Angle	2θ 1/2	Iout=18mA	-	120	-	deg

● **Circuit diagram**

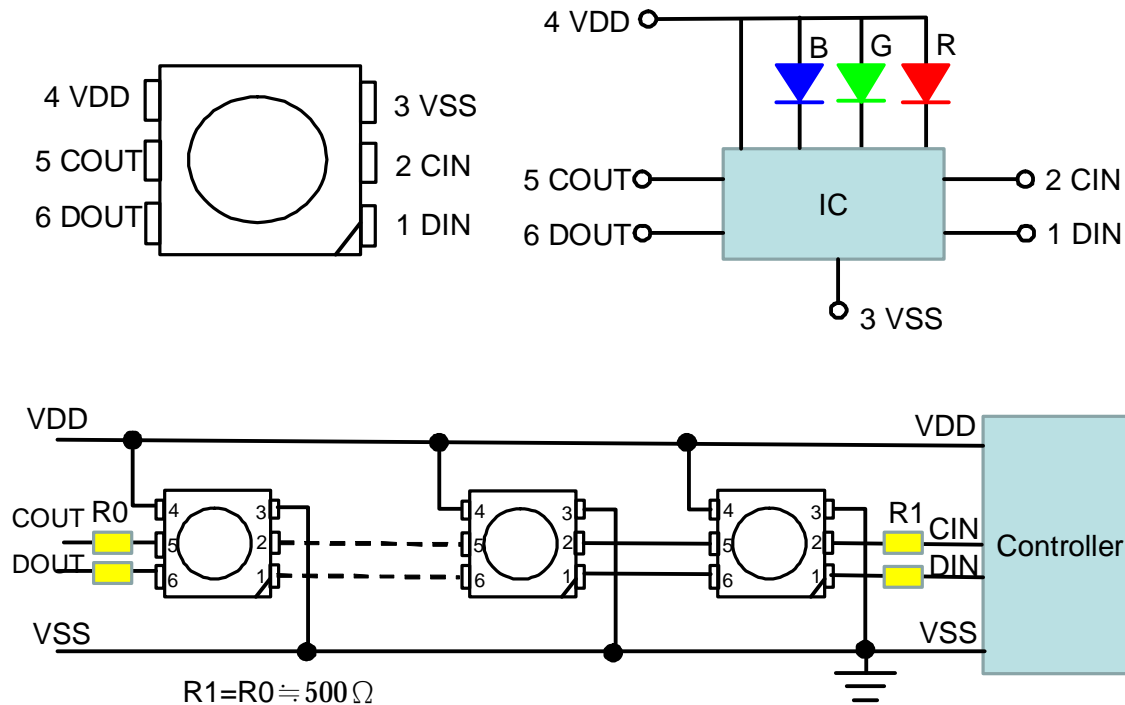

● **IC's function diagram**

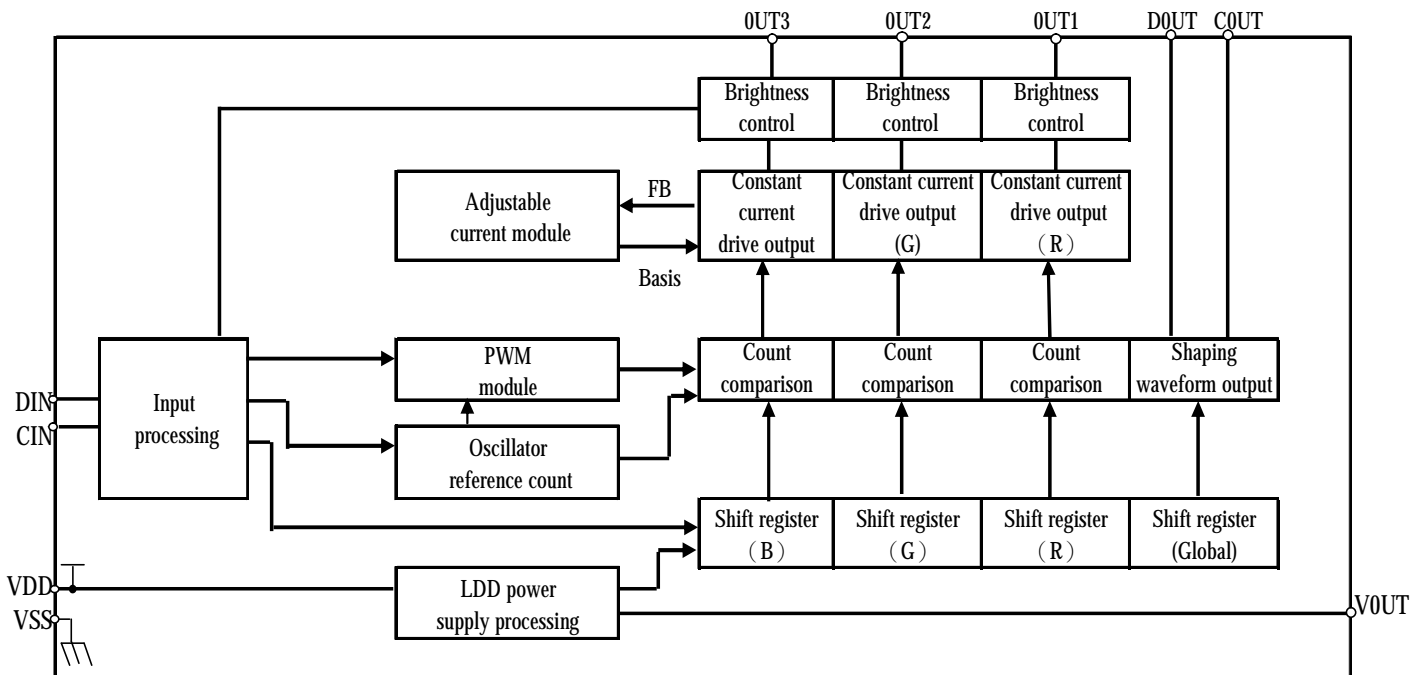

● Sequence Chart

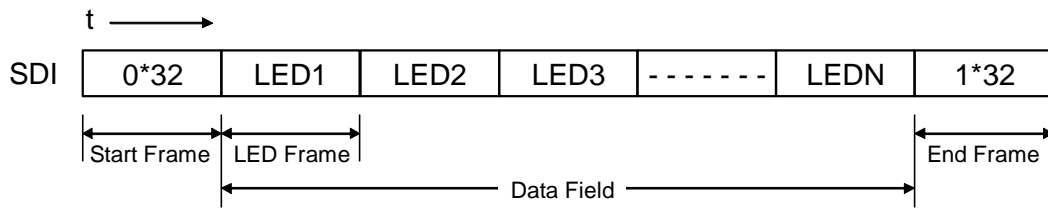

Start Frame 32 Bits

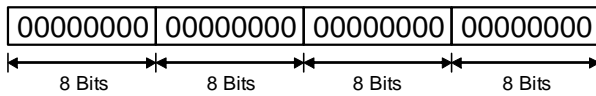

LED Frame 32 Bits

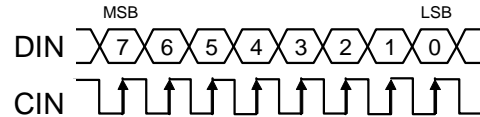
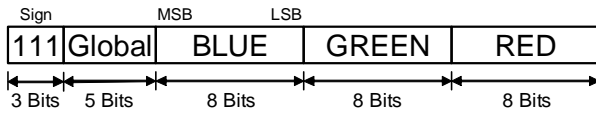

End Frame 32 Bits

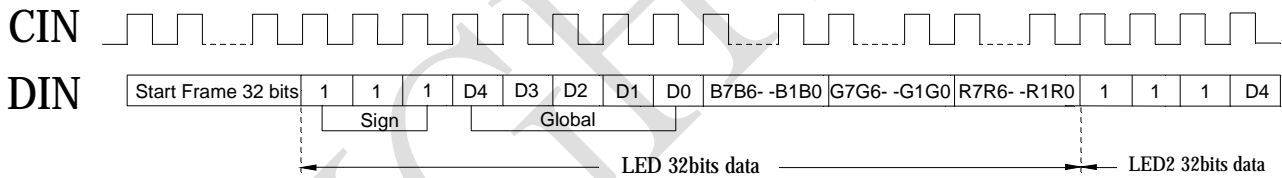
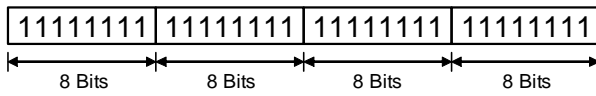

● Global 5-Bit Brightness adjustment

DATA MSB ← → LSB	Driving Current
00000	0/31(min)
00001	1/31
00010	2/31
...	...
11110	30/31
11111	31/31(max)

● B/G/R 8-Bit Gray scale adjustment

DATA MSB ← → LSB	Duty Cycle
00000000	0/255(min)
00000001	1/255
00000010	2/255
...	...
11111110	254/255
11111111	255/255(max)

● Tapping and packaging specifications(Units: mm)

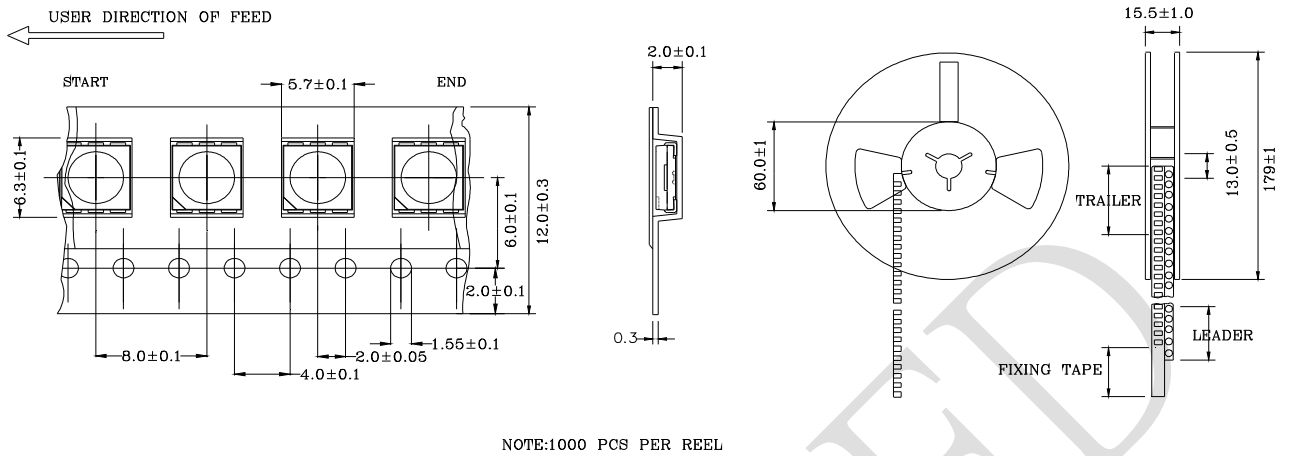

● Package Method: (unit : mm)

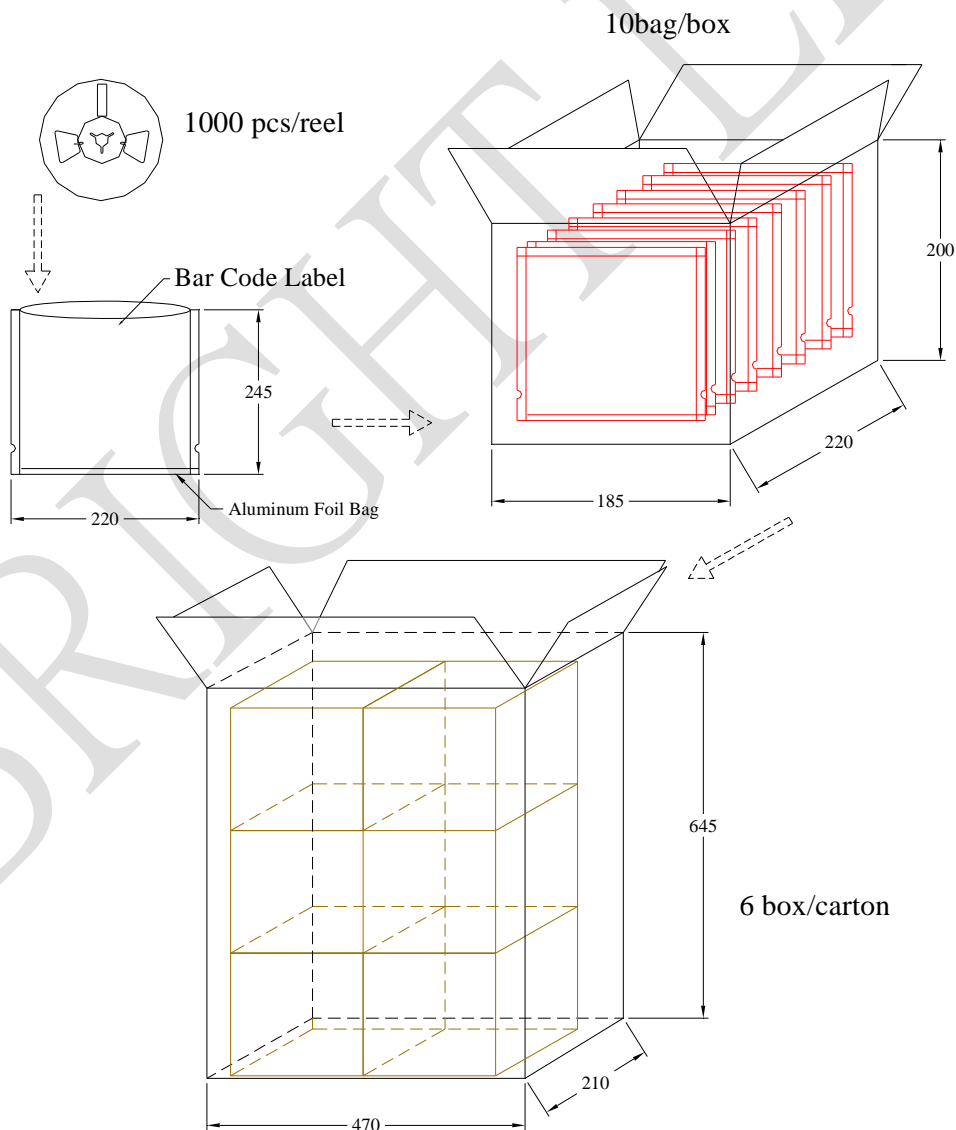



● Reliability Test

Classification	Test Item	Reference Standard	Test Conditions	Result
Endurance Test	Operation Life	MIL-STD-750:1026 MIL-STD-883:1005 JIS-C-7021 :B-1	VDD=5V I _{out} =18mA Ta=Under room temperature Test time=1,000hrs	0/20
	High Temperature High Humidity Storage	MIL-STD-202:103B JIS-C-7021 :B-11	Ta=+65°C±5°C RH=90%-95% Test time=240hrs	0/20
	High Temperature Storage	MIL-STD-883:1008 JIS-C-7021 :B-10	High Ta=+85°C±5°C Test time=1,000hrs	0/20
	Low Temperature Storage	JIS-C-7021 :B-12	Low Ta=-35°C±5°C Test time=1,000hrs	0/20
Environmental Test	Temperature Cycling	MIL-STD-202:107D MIL-STD-750:1051 MIL-STD-883:1010 JIS-C-7021 :A-4	-35°C ~ +25°C ~ +85°C ~ +25°C 60min 20min 60min 20min Test Time=5cycle	0/20
	Thermal Shock	MIL-STD-202:107D MIL-STD-750:1051 MIL-STD-883:1011	-35°C±5°C ~+85°C±5°C 20min 20min Test Time=10cycle	0/20
	Solder Resistance	MIL-STD-202:201A MIL-STD-750:2031 JIS-C-7021 :A-1	Preheating : 140°C -160°C ,within 2 minutes. Operation heating : 260°C (Max.), within 10seconds. (Max.)	0/20

● Judgment criteria of failure for the reliability

Measuring items	Symbol	Measuring conditions	Judgment criteria for failure
Luminous intensity	I _v (mcd)	VDD=5V I _{out} =18mA	Below S ¹ X0.5

- Note: 1. U means the upper limit of specified characteristics. S means initial value.
2. After each test, remove test pieces, wait for 2 hours and test pieces have returned to ambient temperature, then take next measurement.

● Handling Precautions

IR-Reflow

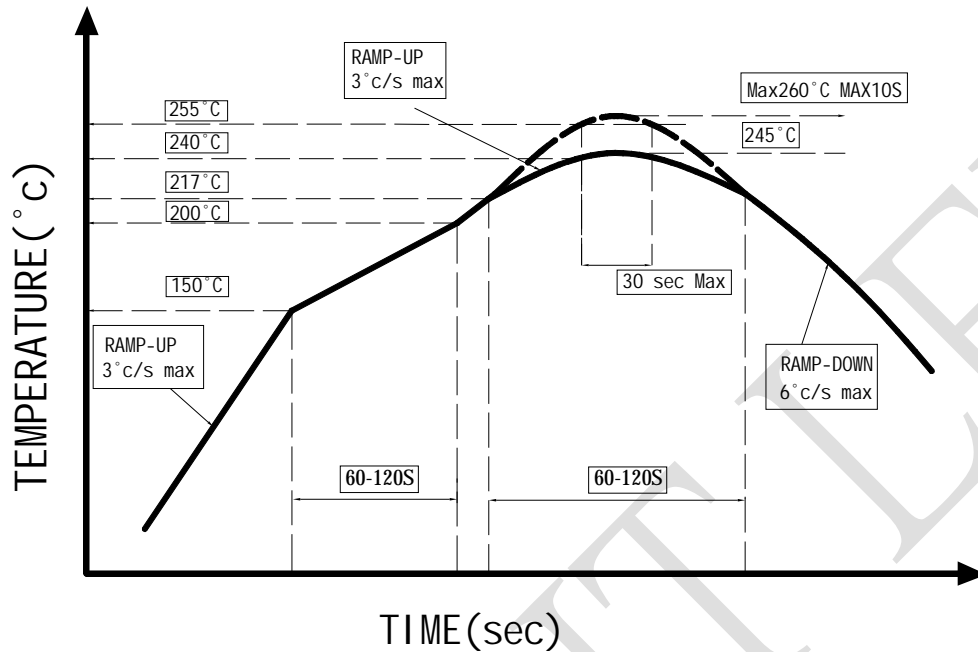

- 1、 Avoid any external stress applied to the resin while the LEDs are at high temperature, especially during soldering.
- 2、 Avoid rapid cooling or any excess vibration during temperature ramp-down process
- 3、 Although the soldering condition is recommended above, soldering at the lowest possible temperature is feasible for the LEDs

● IRON Soldering

350°C Within 3 sec, one time only.

● Handling Precautions

Compare to epoxy encapsulant that is hard and brittle, silicone is softer and flexible. Although its characteristic significantly reduces thermal stress, it is more susceptible to damage by external mechanical force.

As a result, special handling precautions need to be observed during assembly using silicone encapsulated LED products. Failure to comply might lead to damage and premature failure of the LED.

1. Handle the component along the side surfaces by using forceps or appropriate tools. (pic.1)
2. Do not directly touch or handle the silicone lens surface. It may damage the internal circuitry. (pic.2, pic.3)
3. Do not stack together assembled PCBs, containing exposed LEDs. Impact may scratch the silicone lens or damage the internal circuitry. (pic.4)
4. The outer diameter of the SMD pickup nozzle should not exceed the size of the LED to prevent air leaks. The inner diameter of the nozzle should be as large as possible. (pic.5)
5. A pliable material is suggested for the nozzle tip to avoid scratching or damaging the LED surface during pickup. (pic.5)
6. The dimensions of the component must be accurately programmed in the pick-and-place machine to insure precise pickup and avoid damage during production. (pic.5)

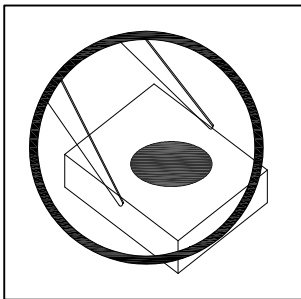

Pic.1

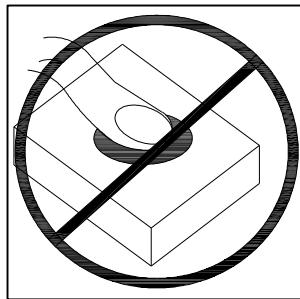

Pic.2

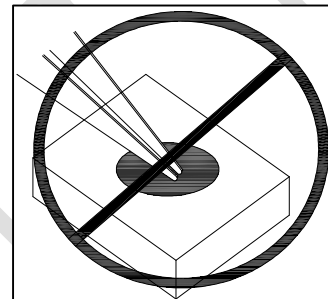

Pic.3

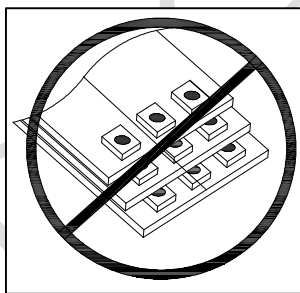

Pic.4

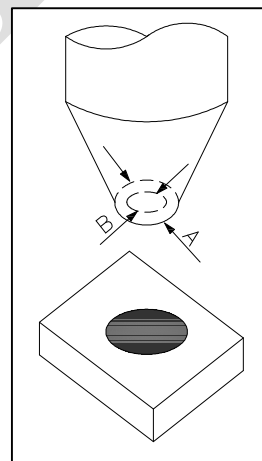

Pic.5



BRIGHT LED ELECTRONICS CORP.

BL-HBGR32L-3-TRB-8

● Notes for designing:

Care must be taken to provide the current limiting resistor in the circuit so as to drive the LEDs within the rated figures. Also, caution should be taken not to overload LEDs with instantaneous voltage at the turning ON and OFF of the circuit.

When using the pulse drive care must be taken to keep the average current within the rated figures. Also, the circuit should be designed so as to be subjected to reverse voltage when turning off the LEDs.

● Storage:

In order to avoid the absorption of moisture, it is recommended to solder LEDs as soon as possible after unpacking the sealed envelope.

If the envelope is still packed, to store it in the environment as following:

- (1) Temperature : 5°C-30°C(41°F) Humidity : RH 60% Max.
- (2) After this bag is opened, devices that will be applied to infrared reflow, vapor-phase reflow, or equivalent soldering process must be:
 - a. Completed within 24 hours.
 - b. Stored at less than 20% RH.
- (3) Devices require baking before mounting, if:
2a or 2b is not met.
- (4) If baking is required, devices must be baked under below conditions:
48 hours at 60°C±5°C.

● Package and Label of Products:

- (1) Package: Products are packed in one bag of 1000 pcs (one taping reel) and a label is attached to each bag.
- (2) Label:

The diagram shows a rectangular label with the following fields and callouts:

- BRIGHT LED LOGO**: Points to the top left corner containing the 'LED' logo and the company name in Chinese and English: '佰鴻工業股份有限公司 BRT BRIGHT LED ELECTRONICS CORP.'
- Part No.**: Points to the field 'Part No.: BL-Hxxxxx-TRB'.
- Quantity**: Points to the field 'Quantity: xxxx PCS'.
- BIN.**: Points to the field 'BIN: x'.
- Sealing Date**: Points to the field 'Sealing date: X X X X X'.
- Manufacture Location**: Points to a small 'x' character located below the label.

Below the 'Sealing date' field, there is a legend for the date format: **XX** Year **XX** Month **XX** Day.